

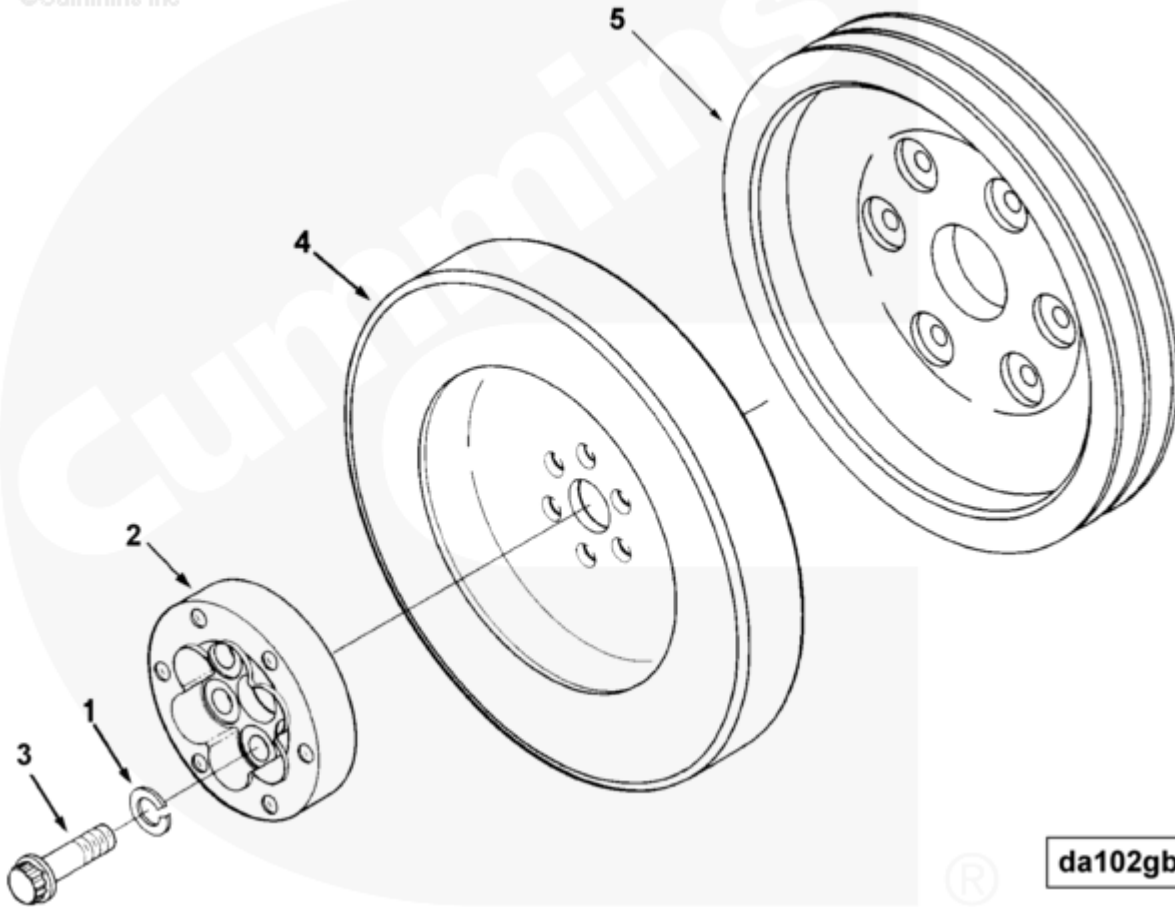

Parts Catalog - Option Detail

Electronic Parts Catalog - Option Detail				
Option	Group	Graphic	Film Card	Date
DA1234-02	01.02.2	da102gb	FF	20-SEP-99
Engines	G855, G855 CM558, GTA855 CM558 (CM2358) G101, N14 CELECT, N14 CELECT PLUS, N14 MECHANICAL, NH/NT 855, QSM11 CM876 M101, QSM11 CM876 M102M, QSN14 CM876 N103, QSN14 CM876 N105, QSNT14 CM876 N102			

©Cummins Inc



SMALL | MEDIUM | LARGE

Cart	Ref No	Part Number	Part Description	Required	Remarks
View My Cart					
		DA1234-02	Vibration Damper		
					Vibration damper and pulley
					arrangement. Required for an
					over running clutch type of

					front power take off (PTO).
					Includes six 1/2in. -13
					threaded bolt holes on a
					4.75in. diameter which can be
					used to mount a flanged
					Drive shaft for a front PTO.
					Refer to AF options to
					specify overrunning clutches
					and flywheel.
<input type="checkbox"/>	1	127316	Plain Washer	6	5/8 in.
<input type="checkbox"/>	2	212112	Power Take-Off Flange	1	
<input type="checkbox"/>	3	212113	Twelve Point Cap Screw	6	5/8 - 18 X 2 1/4 Inch.
<input type="checkbox"/>	4	217323	Vibration Damper	1	
<input type="checkbox"/>	5	3010320	Crankshaft Pulley	1	